

Reference Manual

WasteCaddy *Dumpster Mover*

Read manual carefully before operating machine
Rev. 11/1/16

Model Number:
WasteCaddy Serial Number:

WasteCaddy HD



Safety Precautions

For Safety:

1. Do not operate, maintain, or service machine:
 - Unless trained and authorized.
 - Unless operation manual is read and understood.
 - In flammable or explosive areas.
2. Before operating machine:
 - Make sure all safety devices are in place and operate properly.
3. When maintaining or servicing machine:
 - Disconnect battery connections before working on machine.
 - Avoid contact with battery acid.
 - Avoid moving parts. Do not wear loose jackets, shirts, ties, or sleeves when working on machine.
 - Use DJ Products, Inc. supplied or equivalent replacement parts.
4. Do not transport machine with cover up.

Warning:

Batteries emit hydrogen gas. Explosion or fire can result. Keep sparks and open flame away.

Attention:

The battery charger supplied with the machine shall be grounded while in use to protect the operator from electric shock. This charger is designed for use on a nominal 120 volt circuit and has a grounding plug that resembles the plug illustrated. Make sure the charger is connected to an outlet having the same configuration as the plug. No adapter should be used with this charger. The green conductor in the cord is the ground wire. Never connect this wire to other than the grounding pin of the attachment plug. Store this machine indoors, do not expose to rain. This product is intended for commercial use.

General Specifications:

Electric 36 V DC — (3) 12V batteries
Charger, 110 VAC, 60 HZ

Power Train / Propelling System

36 V DC electric motor
36 V DC controller

Suspension System

Casters —(1) rear, 8 in. (150 mm) dia.
Drive — (2) front, 12 in. (305 mm) dia.

General Machine Dimensions

Length — 44 in. (1067 mm)
Width — 26.4 in. (670 mm)
Height — 41.1 in. (1042 mm)

Machine

Total Weight, with batteries— 700 lbs.

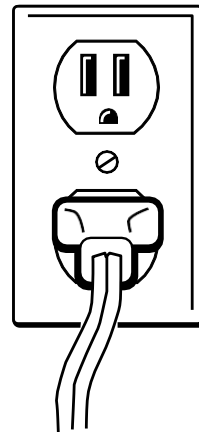

Additional Specifications

Nominal Power	1 hp, 2 hp peak
Mass of most useful configuration	656 lbs. (300 kg)
Maximum draw bar pull	550 lbs. (249 kg)

Use of Machinery

The WasteCaddy is most commonly used with dumpsters having two swivel casters on the front end and two straight casters on the back end. The unit provides easy turning and intricate maneuvering by connecting via provided bracket to the end with swivel casters. Because the unit does not have a lift over the transaxle, it is not able to lift the front of carts, trailers or dumpsters.

Adjustments

Controls:

The handle assembly can easily be adjusted if the machine comes out of neutral and begins to creep. By removing the (4) 5/16" self-threaded screws in the green control box, you will gain access to the control potentiometer. Adjust the potentiometer with a 1/2 SAE wrench. Turning the potentiometer towards the front of the machine will stop the machine from creeping backwards. Turning the potentiometer towards the rear of the machine will stop the machine from creeping forward.

Installing Batteries

1. Make sure the power switch is in the off (0) position.
2. Using the lift handles provided on the battery, place batteries in the machine with the terminal posts shown.

For Safety:

When maintaining or servicing the machine:

- Battery acid can cause burns. Avoid contact with battery acid.
 - When working on or around batteries, wear protective clothing, gloves, and safety glasses.
 - Do not lay metal tools or metal objects on top of the batteries.
 - Only install deep cycle marine style lead acid batteries in your WasteCaddy. The charger is built specifically for lead acid batteries. Any other battery may become overcharged and cause serious damage to the machine or operator.
 - When replacing batteries, you should replace all three batteries. This will assure the batteries will be kept in sync.
3. Remove the nuts from the terminal posts. Connect the wires as shown.
 4. Make sure to attach the positive leads to the positive terminals. Place the nuts on the terminal and tighten securely.

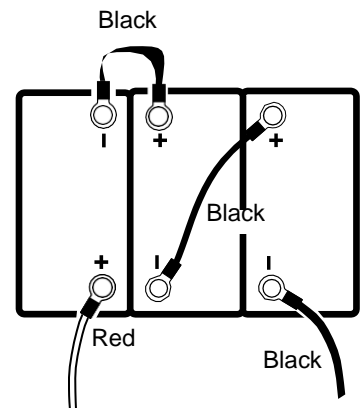

Accessory Panel

1. Power Switch
 - The power switch controls the machine power.
 - Turn key to (1) to turn on the power.
 - Turn key to (0) to turn off the power.
 - The machine batteries must be charged for the machine to have power.
2. Main Circuit Breaker
 - The main circuit breaker protects the motor from overload. If the load is too high, the main circuit breaker will trip and the unit will stop. To reset the circuit breaker, press the circuit breaker reset button on the circuit breaker. It may be necessary to allow the circuit breaker to cool down before resetting, or it may trip again. Reduce the load before resuming. Please review the load limit sections for recommended load limits.
3. Accessory Circuit Breaker
 - The circuit breaker protects control circuit from overload.
4. Voltmeter
 - The voltmeter shows the state of charge of the batteries.

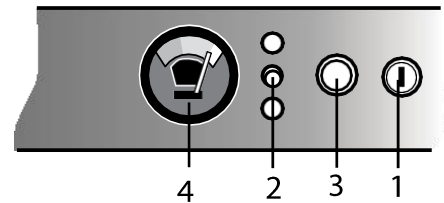

Pre-Operation Checklist

Before operating the machine:

1. Make sure the charge is OFF by unplugging the AC power cord from the wall outlet.
2. Make sure all controls are free and clear of any obstructions.
3. Turn the power switch ON.
4. Make sure the emergency stop switch is working correctly. (Optional)
5. Make sure the safety light is operating correctly. (Optional)
6. Make sure the speed control switch is either in fast or slow speed.
7. Now you are ready to operate. If any of the safety features were not operating correctly please contact:
 - Your Manager
 - Maintenance Personnel
 - Your Service Representative
 - DJ Products, Inc.

Maintenance

The daily and monthly maintenance requirements listed here may be performed without tools by the operator. Instructions for these maintenance requirements are provided in this section of the manual.

Daily:

Perform all duties listed under Pre-Operation Checklist.

Every Month:

Add distilled water if needed. Water should be just over the top of the cells in the batteries. This is not necessary if your unit has maintenance free batteries.

Every Three Months:

Lubricate the castor bearings with grease.
Check and tighten all fasteners and hardware.
Check, tighten, and lubricate battery posts and cables.

Charging Batteries

The batteries have an approximately eight hour run-time when fully charged. The batteries take about eight hours to charge after they have been fully discharged. The battery charger has an automatic timer that will turn off the charger when the batteries reach full charge. The batteries should be charged after every eight hours of machine operation.

To charge the batteries:

1. Move the machine to a flat, dry surface in a well ventilated room.
2. Open the machine cover (depending on model).
3. Check the water level in the battery cells. If the level is low, add just enough distilled water to cover plates. **DO NOT OVERFILL.**
4. Wipe off tops of batteries with a cloth.
5. Connect this charger to the machine.
6. Plug the charger into a wall outlet.

Service Policy

Whenever ordering parts or requesting any type of service, specify:

1. The model of the machine
2. Serial number
3. The part number
4. The part description

Load Limits

The WasteCaddy is specifically designed to push or pull dumpster carts and any like device resembling a cart. You should never operate the WasteCaddy:

- With an operator under the age of 16.
- With an operator sitting or riding on the WasteCaddy or any carts it may be pushing.
- With added weight not specifically added by DJ Products, Inc. or a certified service rep.
- With the hood or panels in the open position.
- Without being properly trained by a supervisor.
- In severe weather.
- With a known feature not working correctly.
- While on any medicine that may impair your vision or reflexes.

By disregarding any of these limits, use may cause damage to the operator, your customer, the WasteCaddy, walls, doorways or property.

Disregarding any of these limits will void your warranty in case the WasteCaddy is damaged.

Parts LIST				
ITEM	QTY	PART NO.	REV	DESCRIPTION
49	1	590199	D	WASTE CADDY BRCKET WELDMENT
48	1	590340	A	WASTE CADDY BRCKET WELDMENT
47	1	WCA-000	A	WASTE CADDY ARM WELDMENT
46	1	300166	A	SERIAL DATA DISPLAY
45	1	500187-05		HIGH LOW SWITCH
44	1	300250	A	3hp Controler
43	1	508801-410	C	3HP TRANSAXLE
42	1	501229	C	TRANSAXLE BRACE 3HP, CC5W
41	2	506009	D	3 horse Power Transaxle Clamp
40	2	501218	L	TRANSAXLE BRACKET WELDMENT 3HP
39	1	706025	B	BATTERY TRAY
38	1	500138	B	HANDLE BAR
37	1	500519-07	A	3 BANK BATTERY CHARGER, 15A
36	1	500345-03	A	100 AMP FUSE BLOCK
35	1	500345-02	A	100A FUSE
34	1	500145-01		KEY ASSY (CHROME) UL RATED
33	1	500146	-	20 AMP CIRCUIT BRAKER
32	1	JB-0001	A	NEGITIVE POWER BLK
31	1	500149		SOLENOID
30	1	590000	C	CASTER BRACKET, WELDMENT
29	1	500359-051	A	SNAP PIN
28	2	500407-02	B	5TH WHEEL ARM SLEEVE AND FLANGE BEARING
27	2	500407-01	A	5TH WHEEL ARM TRUST WASHER
26	1	500309	F	ARM 5TH WHEEL 17.5
25	1	500359	E	5TH WHEEL BRACKET WELDMENT
24	1	706013	C	WEIGHT BOX SIDE COVER
23	1	706012	B	COMPONENT COVER
22	1	706011	B	BATTERY COMPARTMENT COVER
21	15	706010	B	1/2" CART CADDY LITE HD WEIGHT
20	5	500152	A	Handle Bar Grip
19	1	500142	A	POT AND HARNESS ASSY
18	2	500414		SWITCH, MOUNTING PANEL END
17	1	500405-01	-	LIFT SWITCH
16	1	500406-02	-	HORN SWITCH
15	1	500187	A	E-STOP ASSY
14	1	500262	B	E- STOP GAURD
13	1	500140	A	HANDLE BAR GEAR-222079
12	2	500137	A	HANDLE BAR GEAR BUSHING
11	1	500297		1" HANDLE BAR GEAR SPACER
10	1	500296	A	TORSION SPRING
9	1	500277	A	1.2 HANDLE BAR GEAR SPACER
8	1	500140-01	a	TORSION SPRING CENTERING BOLT
7	1	500139		POT GEAR
6	1	508013	K	Universal Cart Caddy Control Box Cover
5	1	508012	F	Universal Cart Caddy Control Box Weldment
4	3	500155-07	A	NON SEALED, BATTERY
3	2	300183	B	CASTER 8 INCH SWIVEL
2	2	500129-01	A	FOAM FILLED NON-MARKING TIRE, RIM
1	1	706003	I	CART CADDY LITE HD FRAME WELDMENT

REVISION BLOCK				
REV	DESCRIPTION	DATE	BY	SHEET
A	NEW RELEASE	1/11/16	PH	--
B	UPDATE FOR FRAME CHANGES	4/1/16	PH	ALL

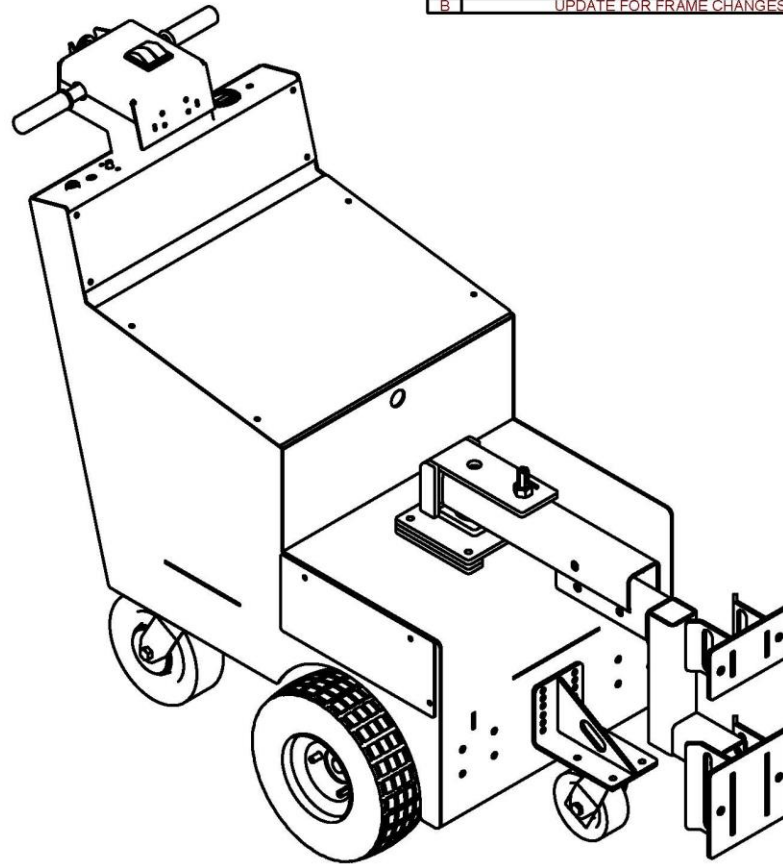

UNLESS OTHERWISE SPECIFIED: -TOLERANCE-		DJ PRODUCTS Inc. 1009 4TH STREET N.W. LITTLE FALLS MN 56345		PRODUCT MANAGER / ENGINEER:	
BY ACCEPTING THIS DRAWING THE RECIPIENT ACKNOWLEDGES AND CERTIFIES THAT PRODUCT DESIGN DISCLOSED ARE PROPRIETARY AND BELONGS SOLELY TO DJ PRODUCTS ALL RIGHTS OF DESIGN OR INVENTION ARE RESERVED.	-INCHES-	MATERIAL:		DRAFTER/DESIGNER:	
0±	1			PAT H	
00±	03			SCALE:	DATE:
000±	010	NAME:		1/11/2016	
ANGLES±	3°	WASTE CADDY HD ASSEMBLY		PART NO.	REV. NO.
DRAFT±	3°	PROJECT:		706100	B
FINISH PART:	TIME STAMP:	FILENAME AND PATH:		Sheet:	
	21Sep09 - 11:17am	C:\Work\Engineering Design\10 Unit Folder\706000 CART CADDY LITE HD\706100 WAS TE CADDY SHP ASSEMBLY\706100.iam		1 OF 2	

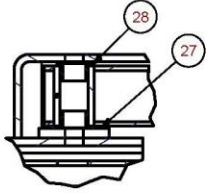

DETAIL B
SCALE 1 / 6

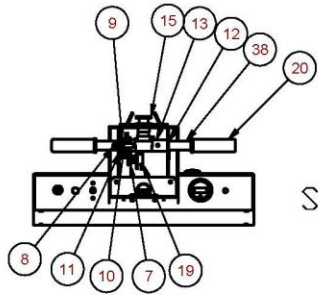

VIEW A-A
SCALE 1 / 12

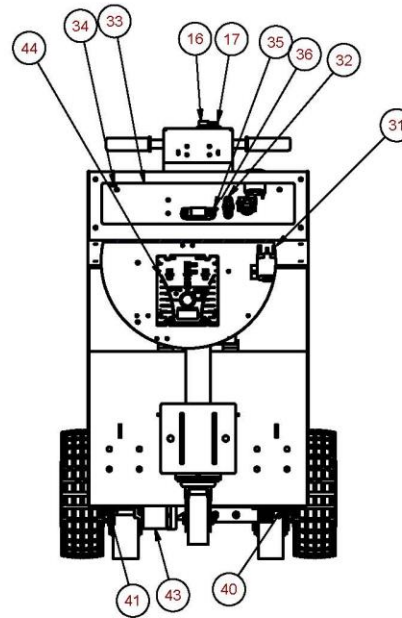
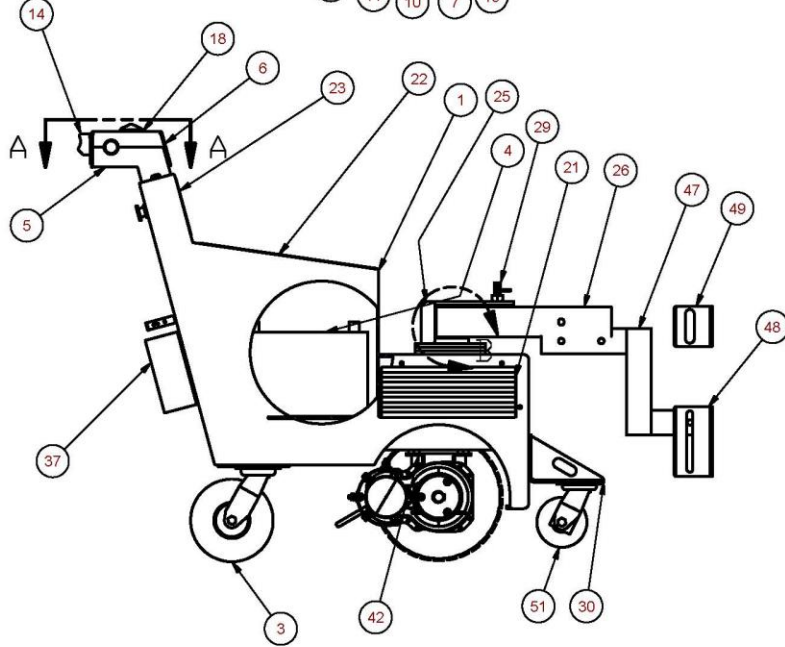

REVISION BLOCK				
REV	DESCRIPTION	DATE	BY	SHEET
A	NEW RELEASE	1/11/16	PH	ALL
B	UPDATE FOR FRAME CHANGES	4/1/16	PH	ALL

UNLESS OTHERWISE SPECIFIED: -TOLERANCE-		DJ PRODUCTS Inc. 1009 4TH STREET N.W. LITTLE FALLS MN 56345		PRODUCT MANAGER / ENGINEER:	
BY ACCEPTING THIS DRAWING THE RECIPIENT ACKNOWLEDGES AND STIPULATES THAT PRODUCT DESIGNS ENCLOSED ARE PROPRIETARY AND BELONG SOLELY TO DJ PRODUCTS. ALL RIGHTS OF DESIGN OR INVENTION ARE RESERVED.		-INCHES-		DRAFTER/DESIGNER:	
FINISH PART	TIME STAMP	SHEET SIZE	MATERIAL	SCALE:	DATE:
	21Sep09 - 11:17am	B			1/11/2016
PROJECT:			NAME:		PART NO.
PROJECT:			NAME:		REV NO.
PROJECT:			NAME:		706100
PROJECT:			NAME:		B
FILENAME AND PATH: C:\Work\Engineering Design\110\Unk\Folder\706000 CART CADDY LITE HD\706100 WASTE CADDY 3HP ASSEMBLY\706100.dwg					Sheet
					2 OF 2

Operating and Training Instructions for the WasteCaddy

Please make as many copies as needed for training purposes.

1. Operator has been shown and understands that the key switch and the safety stop switch must be turned on and the battery indicator gauge must be in the green/white position before the WasteCaddy will operate.

X _____

2. Operator has been shown and understands that the WasteCaddy has variable speed handle bar twist grips that will operate the unit between 0-3 mph forward and 0-1.5 backward. Operator understands that allowing the handlebars to spring back to neutral *or* pushing the safety stop switch will stop the unit and load. The unit also has a variable-control speed gauge that limits both speed and power.

X _____

3. Operator has been shown and understands that the 5th Wheel Arm/Dumpster Bar is capable of pivoting 90 degrees both left and right, and has a locking-pin mechanism that will keep the Arm/Dumpster Bar in a locked, forward position. The 5th Wheel Arm/Dumpster Bar should be in the locked, forward position when connecting to the dumpster bracket. When moving a dumpster, the locking-pin mechanism should be raised, allowing for turning and maneuverability. When NOT connected to a dumpster, the 5th Wheel Arm/Dumpster Bar should be kept in the **locked position** to avoid damaging property or injuring people.

X _____

4. Operator has been shown and understands that using the handle bar to pivot the WasteCaddy to the left or right will all the operator to turn the load. Operator understands that both hands should be on the handle bar when *pushing* a load. When *pulling* a load, the operator should have one hand on the handle bar, and should face forward (the direction the load is being pulled) while walking alongside the WasteCaddy.

X _____

5. Operator has been shown and understands that when the unit is not in use, THE KEY MUST BE TURNED TO THE **OFF POSITION**, and the unit should be plugged into an outlet for charging. Before resuming use of the WasteCaddy, the automatic charger must be unplugged and the battery-charge gauge fully back in the green/white. If the unit is not plugged in, and key is not turned off, *the unit will continue to draw from the battery while not in use*, and batteries may be drained before next use, rendering the unit in-operable.

X _____

6. Operator understands that the WasteCaddy brake can be disengaged to allow the unit to “free-wheel” in situations where the unit is not operational. This is done by pushing the silver lever, near the drive tire, underneath the unit, down, “clicking” into the 7 o’clock position. Lift lever back into the 9 o’clock position, and turn unit off/on to resume operation.

X _____

7. Operator has been shown and understands that when the safety stop switch bumps into the operator and is depressed, the unit stops. The unit will not travel backward, only forward in a slow manner as to unpin the operator if necessary. Operator must twist the safety stop switch in clockwise direction to release the switch before the unit becomes fully operational again. When the safety stop is depressed on the WasteCaddy HD, the unit will not move forward or backward until the safety stop switch is released.

X _____

8. Operator has been shown and understands that when the battery gauge is in the red, it should be plugged into the automatic charger until the unit is fully charged. The automatic charger must be unplugged and the gauge fully back in the green/white before the WasteCaddy is put back into operation.

X _____

Troubleshooting Guide (Questions and Answers)

Q. My machine only goes forward slowly and does not go in reverse.

A. The red e-stop button is pushed in or the e-stop is not hooked up. Twist the red button clockwise to release the button. Check e-stop wiring, there could be a loose or disconnected wire.

Q. The WasteCaddy turns on and powers up but does not move.

A. 1. Make sure wires number 9 and 14 are plugged into the controller and are making a good connection.
2. Make sure motor connector under the machine is plugged in and is not damaged.
3. Check to make sure the 5k potentiometer in the handle bar is centered. Test the black and red wire, the center position is 2.5 ohm, when not moving the handle bars should read between 2.4k ohm and 2.6k ohm. If it is out of that range the machine will not move.
4. Test controller for power. You should have at least 36 volts coming into the controller at the b+ and b- terminals. Now check voltage at the motor connector under the machine. With the machine on and rotating the handle bars all the way forward or reverse you should have the same voltage as you did going to the controller. If you do not the controller could be bad.

Q. When I am done running the machine and I let go of the handle bars the machine slowly moves on its own.

A. The potentiometer in the handle bar is slightly out of center. Center to 2.5k ohm by testing the black and red wires on the potentiometer and rotating it to whatever direction is needed.

Q. When I turn the key on, nothing happens at all.

A. If the voltmeter doesn't come on or you don't hear the contactor "click" one of three things could be bad. Check the battery voltage across all three batteries; you should have at least 36 volts. If that is OK either the contactor is not working or the key switch is not working. To bypass the key switch take the two wires going to the key switch and touch them together, if the key switch is bad the machine should turn on. To bypass the contactor please call DJ Products, Inc. service dept. for further tests.

Q. When I plug the onboard Minnkota charger into the wall one or more of the banks say check connection.

A. Check the fuse on that bank(s) to see if it is blown. Check the connection to the battery terminal. If both of these things are OK the battery voltage on the bank(s) is probably below 9 volts. The charger has a safety feature on it, when the battery voltage drops below 9 volts the charger says check connection and shuts down that bank. Either charge that battery with an external charger to bring the voltage up or cycle the power on the charger by plugging in the charger and unplugging it every 5 to 10 minutes until that bank shows it in charging mode.

Q. When I plug in my onboard Minnkota charger no lights come on at all.

A. Try plugging it into a different outlet, if that doesn't work call DJ Products, Inc., you may need a new charger.

Troubleshooting Guide (Questions and Answers)

Q. When I turn on the handle bar I can hear the machine running but it doesn't move.

A. The gear at the end of the DC drive motor has either fallen off or broke. Take the drive motor off the transaxle to inspect the gear. At the end of the motor there should be a shaft with a gear and a clip holding it on. When taking the motor off you might want to tilt the machine at a slight angle to help prevent oil from leaking out of the transaxle. Note: Do not tip it too far, the batteries may leak acid out. If some oil leaks out you can refill it with 80 or 90 weight gear oil.

Q. When I press the optional horn button the horn does not sound.

A. Check the connections to the horn and the horn switch. If OK you can hook the horn directly to 36 volts, if the horn sounds then your switch is bad.

Q. When I rotate the handle bar, it does not snap back into the center position.

A. The torsion spring has either slipped off the centering bolt or the spring has broken. Take the screws out of the control box to pull the box apart, the bottom part will pull completely off and the top part can rotate up. Inspect the torsion spring to make sure it is in the proper position.

Q. The WasteCaddy shows full power until I start using it, then the needle on the voltmeter drops down into red.

A. You probably have one or more bad batteries. You can check the batteries with a multi-meter but a load cell tester is preferred. You should have 12 volts on each of the batteries; you may have a bad cell in one or more of the batteries causing the machine to lose power.

Q. When I am pulling/pushing with the WasteCaddy, I hear a pop and the machine stops moving.

A. The circuit breaker on the machine is blown, turn the machine off and push in the circuit breaker, it should reset itself. If this happens more often the circuit breaker could be wearing out and you may need to purchase a new breaker.

Q. The machine is moving a lot slower than normal in both directions.

A. Make sure the variable-control speed potentiometer on the instrument panel is turned up to the number 2 or 3. If it is turned set too low, the machine will barely move. Check voltage to make sure you have 36 volts across the three batteries.

Q. My voltmeter shows full power even when I turn the key switch to the off position.

A. There is a diode in the main harness next to the key switch wires, if your voltmeter shows full power and the machine works with the keys off the diode is bad. Call DJ Products, Inc. to order a new one.

Warranty

IMPORTANT: Read this entire Limited Warranty before using the WasteCaddy™ product. The WasteCaddy™ product (or other DJ Products Inc. product-collectively referred to herein as the “Product”) manufactured by DJ Products Inc., a Minnesota corporation (“Manufacturer”) is believed to be reliable if the directions for its use, maintenance, and operating procedures are followed carefully. However, it is impossible to eliminate all risks inherently associated with the use of this Product. Risk of failure, including personal injury, dismemberment, injury to property or even death, may result from misuse, abuse, neglect, negligent use, accidental or intentional damage, ordinary wear and tear, violation or omission of standard operating procedures, improper maintenance, failure to perform routine and preventive maintenance, alterations, additions and/or modifications to the Product, use by any individual not fully trained or fully authorized, and improper training of the operator, all of which are beyond the control of the Manufacturer. All such risks are fully assumed by the purchaser/customer of the Product (“Customer”).

Manufacturer offers a limited warranty (the “Limited Warranty”) to each Customer who is the original purchaser of this Product that, effective for a period of one year (“Limited Warranty Period”) from the date of delivery of the Product to the Customer, that the Product is free from defects in material or workmanship in normal use and service. Should any Product prove not to conform to foregoing Limited Warranty, the remedies of Customer for any breach of the foregoing Limited Warranty shall be limited to the repair or replacement of the Product. **IN NO EVENT SHALL MANUFACTURER’S OBLIGATIONS PURSUANT TO THIS LIMITED WARRANTY EXCEED THE AMOUNT PAID TO THE MANUFACTURER BY THE CUSTOMER FOR THE PARTICULAR PRODUCT INVOLVED, TO THE EXCLUSION OF ALL OTHER REMEDIES OR LIMITATIONS, INCIDENTAL OR CONSEQUENTIAL DAMAGES.** The Limited warranty, which is Customer’s **EXCLUSIVE REMEDY**, shall be **FURTHER LIMITED** as follows:

1. If the defect in material or workmanship is disclosed to the Manufacturer by the Customer within the first ninety (90) days following delivery of the Product to the Customer, the Limited Warranty shall be the full cost of the labor and parts to repair or replace the defective Product or component parts thereof.
2. If the defect in material or workmanship is disclosed to the Manufacturer by the Customer prior to the expiration of the Limited Warranty Period but more than ninety (90) days following the delivery of the Product, the Limited Warranty shall be the Manufacturer’s cost of the replacement parts (excluding repair labor) required to repair the defective Product or component part. Any warranty repair or replacement of Products or defective component parts shall occur at the Manufacturer’s (or authorized service provider’s) place of business. In order to obtain warranty service, the Customer must return the defective Product to the Manufacturer within the Warranty Period, together with proof of purchase by Customer establishing date of delivery, with freight charges and applicable costs of repair, if any, prepaid, which Product the Manufacturer shall ship, prepaid, any repaired or replaced product covered by the Limited Warranty, to the Customer’s facility located within the continental United States.

(continued on next page)

Warranty Continued

The Limited Warranty is invalid if the factory-applied serial number has been altered or removed from the Product. The Limited Warranty does not cover cosmetic damage or damage due to acts of God, accident, misuse, abuse, neglect, negligent use, accidental or intentional damage, ordinary wear and tear, violation or omission of standard operating procedures, improper maintenance, failure to perform routine and preventative maintenance, alterations, additions and/or modifications to the Product, use by any individual not a fully trained and fully authorized operator, and improper training of the operator, or repair or attempted repair by anyone other than Manufacturer or its authorized agents, nor to any Product which is leased or used as rental equipment. The occurrence of any of the foregoing voids the Limited Warranty.

This Limited Warranty does not cover Customer instruction or training.

THIS LIMITED WARRANTY PROGRAM IS EXCLUSIVE AND IS GIVEN AND ACCEPTED IN LIEU OF ANY AND ALL OTHER WARRANTIES, WHETHER WRITTEN OR ORAL, EXPRESSED OR IMPLIED OR INFERABLE FROM THE COURSE OF DEALING OR USAGE OF TRADE, INCLUDING, WITHOUT LIMITATION, THE IMPLIED WARRANTY OF MERCHANTABILITY AND THE IMPLIED WARRANTY OF FITNESS FOR A PARTICULAR PURPOSE AND ANY IMPLIED WARRANTY ARISING FROM PERFORMANCE, COURSE OF DEALING OR USAGE OF TRADE, AND ALL OTHER OBLIGATIONS, LIABILITIES, RIGHTS, CLAIMS OR REMEDIES, INCLUDING ANY RIGHT IN CONTRACT, TORT, STRICT LIABILITY OR ANY RIGHT ARISING FROM MANUFACTURER'S NEGLIGENCE, ACTUAL OR IMPUTED. FOR CLARIFICATION ONLY (AND NOT IN ANY WAY TO EXPAND THE FOREGOING EXCLUSIVE REMEDIES):

(A) UNDER NO CIRCUMSTANCES WILL MANUFACTURER BE LIABLE FOR LOST PROFITS OR ANY OTHER INCIDENTAL, CONSEQUENTIAL, SPECIAL OR INDIRECT DAMAGES RESULTING FROM THE PURCHASE OR USE OF THIS PRODUCT, INCLUDING, WITHOUT LIMITATION, ECONOMIC LOSS, COST OF CAPITAL, CLAIMS OF CUSTOMERS FOR FAILURE OF SUPPLY OR LOSS OF USE OR DAMAGE TO PERSONS OR TO OTHER PROPERTY, NOTWITHSTANDING THE FACT THAT THE MANUFACTURER HAS BEEN ADVISED OF THE POSSIBILITY OF SUCH DAMAGES; (B) THE TOTAL LIABILITY OF THE MANUFACTURER TO CUSTOMER SHALL NOT EXCEED THE TOTAL PURCHASE PRICE PAID BY THE DISTRIBUTOR TO MANUFACTURER FOR THE PARTICULAR PRODUCT INVOLVED; AND (C) NO AGREEMENT VARYING OR EXTENDING THE FOREGOING WARRANTIES, REMEDIES OR LIMITATIONS WILL BE BINDING UPON THE MANUFACTURER UNLESS IN WRITING AND SIGNED BY A DULY AUTHORIZED CORPORATE OFFICER OF THE MANUFACTURER.

If any term or condition of this Limited Warranty program is in violation of applicable local, state, or federal law, this Limited Warranty program shall not be voided in its entirety, but rather, the court, or other appropriate authority having jurisdiction in the matter, shall rewrite and reform the Limited Warranty to the minimum extent required so as to be permitted under applicable law.